

FMP SERIES

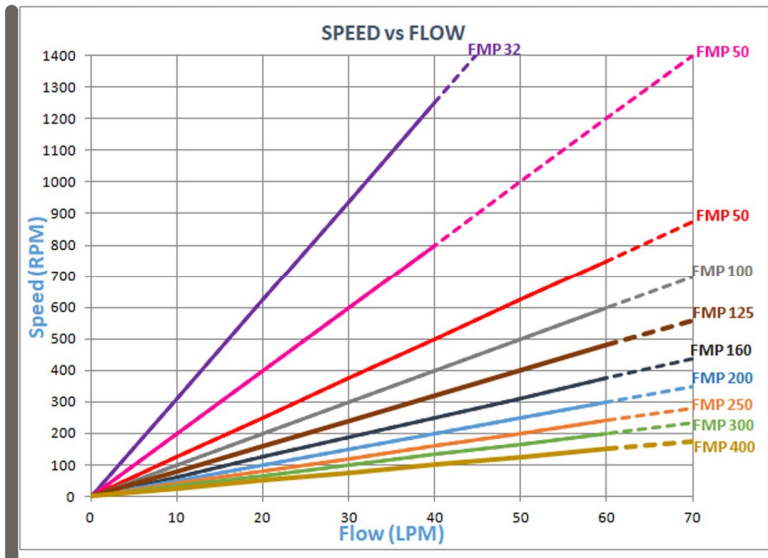

"Rotodyne" FMP Series Gerotor Hydraulic Motors are suitable for a wide range of applications in machine tool, Road Sweepers, Conveyers, Indexers and Self Centering Devices etc. These motors incorporate the proven orbit principle to provide high torque at low speeds.

	FMP 32	FMP 50	FMP 80	FMP 100	FMP 125	FMP 160	FMP 200	FMP 250	FMP 300	FMP 400
Displacement (cc/rev)	32	50	80	100	125	160	200	250	300	400
Speed (Max) (rpm)	1100	800	750	600	480	375	300	240	200	150
Torque (Max) Kg.M	4	6	10	13	17	21	23	25	25	32
Flow (Max) (Lpm)	40	40	60	60	60	60	60	60	60	60
Pressure (Max) (Kg/cm ²)	100	100	100	100	100	100	90	75	65	60
Output (Max) (HP)	4.5	4.5	6	6.5	6.5	6.5	6	5	4	3.8
Length 'L' (mm)	127	129	133	136	138	145	152	157	164	169
Weight (Kg)	5.7	5.8	6	6.1	6.1	6.2	6.4	6.7	7	7.4

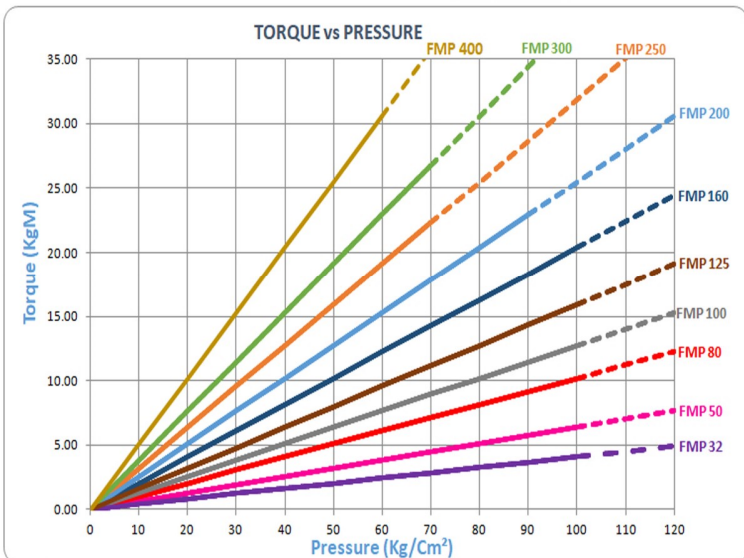
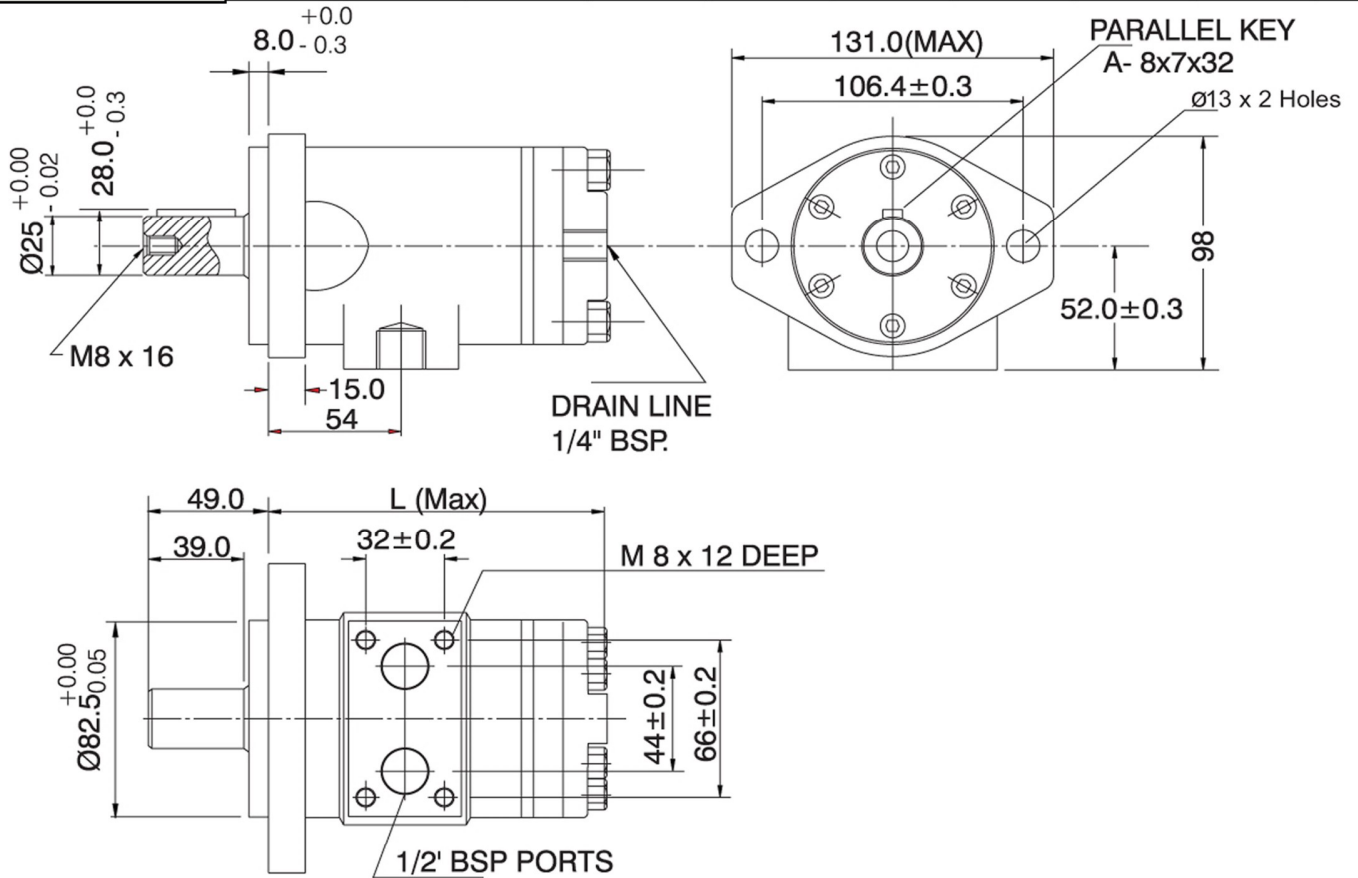

Note: Dotted Lines Indicate Operation in this region is not recommended for continuous application